

VF 60

Wire cable tray heavy duty

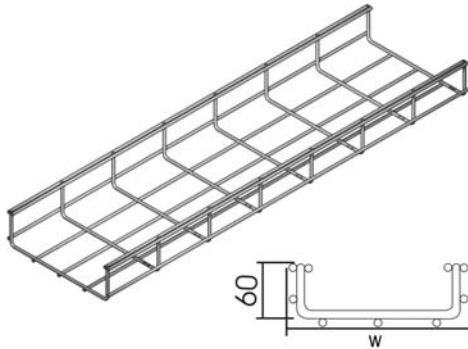

Screen : 50 x 100 mm
Thread : Ø 5 mm

On Demand	Powder coating / Duplex System
Length	3000 mm
Standard finish	Electro zinc-plated
Optional finish 1	Hot-dip galvanised

1	Reference	Height	Width	Thickness	Length	kg/m	Packaging	Stock	Unit
HD	- VF 60*050	60	50	-	3000	0,950	30	✓	m
HD	- VF 60*100	60	100	-	3000	1,270	30	✓	m
HD	- VF 60*150	60	150	-	3000	1,340	20	✓	m
HD	- VF 60*200	60	200	-	3000	1,530	30	✓	m
HD	- VF 60*300	60	300	-	3000	1,920	30	✓	m
HD	- VF 60*400	60	400	-	3000	2,300	30	✓	m
HD	- VF 60*500	60	500	-	3000	2,690	30	✓	m
HD	- VF 60*600	60	600	-	3000	3,080	30	✓	m

To fix with:

HD	Reference	Height	Width	Thickness	Length	kg/m	Packaging	Stock	Unit
HD	- VFK	-	-	-	-	0,020	100	✓	piece
HD	- VFKS	60	-	-	-	0,270	10	✓	piece
HD	- KPVF	60	-	-	-	0,100	30	✓	piece

More technical specifications for this product can be found at the end of this chapter.

VF 60

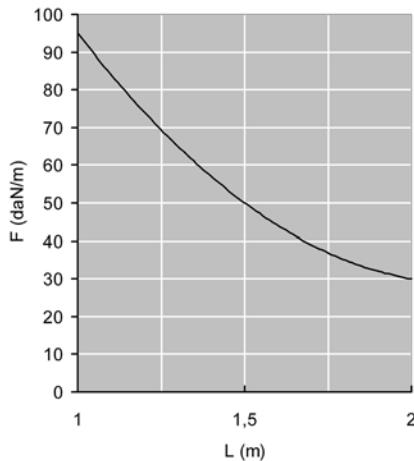

LOAD DIAGRAM

Graph valid for VF 60. This diagram illustrates the permissible uniformly distributed loads applied to multiple supports. They comply with IEC 61537 par 10.3.3 test type III with connection to 1/5 of the span.

F = max. admissible load (daN/m)
L = support distance (m)

Max. deflection (m) = L/100

VF 85

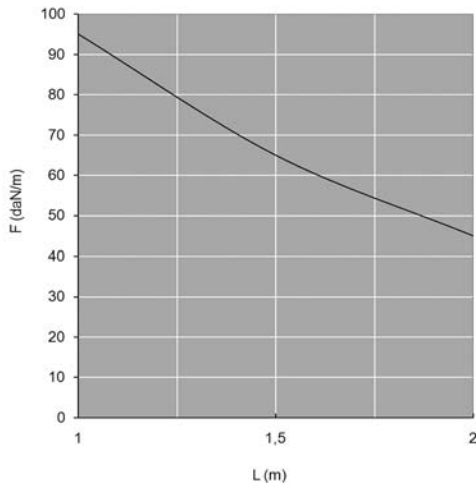

LOAD DIAGRAM

Graph valid for VF 85. This diagram illustrates the permissible uniformly distributed loads applied to multiple supports. They comply with IEC 61537 par 10.3.3 test type III with connection to 1/5 of the span.

F = max. admissible load (daN/m)
L = support distance (m)

Max. deflection (m) = L/100

VF 110

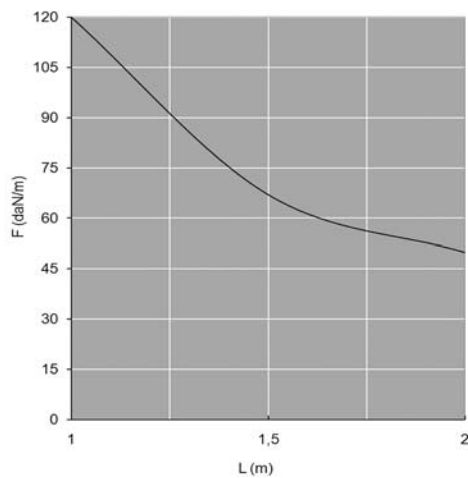

LOAD DIAGRAM

Graph valid for VF 110. This diagram illustrates the permissible uniformly distributed loads applied to multiple supports. They comply with IEC 61537 par 10.3.3 test type III with connection to 1/5 of the span.

F = max. admissible load (daN/m)
L = support distance (m)

Max. deflection (m) = L/100