

KL 85

Cable ladder

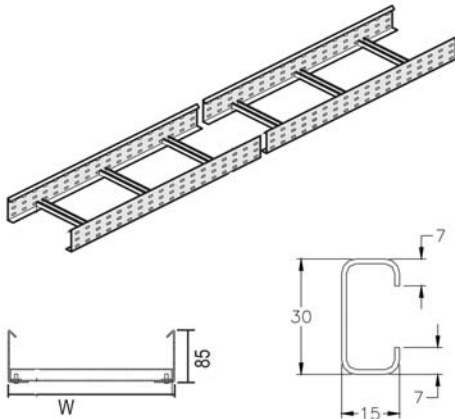

Side walls : perforated L-profile
C-rungs

Useful inner height	70 mm
Rung distance	300 mm
On Demand	Powder coating / Duplex System
Length	3000 mm
Standard finish	Pre-galvanised
Optional finish 1	Hot-dip galvanised

1	Reference	Height	Width	Thickness	Length	kg/m	Packaging	Stock	Unit
HD	- KL 85*200	85	200	-	3000	2,770	18	-	m
HD	- KL 85*300	85	300	-	3000	2,970	18	-	m
HD	- KL 85*400	85	400	-	3000	3,170	18	-	m
HD	- KL 85*500	85	500	-	3000	3,370	18	-	m
HD	- KL 85*600	85	600	-	3000	3,600	18	-	m

To fix with:

HD	- VM 6*10	-	-	M6	10	0,010	250	✓	piece
HD	- V 85*200	85	200	-	-	0,130	48	✓	piece

More technical specifications for this product can be found at the end of this chapter.

CHARACTERISTICS

- light weight
- strong
- fixation of the partition SLOS 60 in the cable ladder by means of a sliding nut GM 6 and round head bolt RB 6*10
- all accessories of the cable tray height 60 mm can also be mounted on this KL cable ladder
- in case of cutting the cable ladder, it is not necessary to perforate any further coupling holes.

TECHNICAL INFORMATION

The side walls are L-profiles with return flange. Continuous perforation of the side-wall. The rungs are C-profiles and placed in the side walls with an interval of 300 mm.

They are placed by means of cold junction. The openings of the rungs are directed upwards.

Order the necessary coupling plates (2 per length), bolts and nuts separately.

KL 60

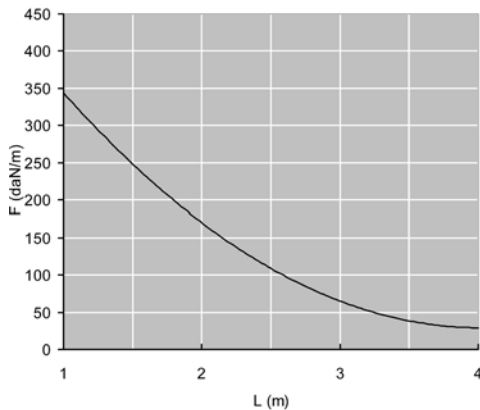

LOAD DIAGRAM

Graph valid for KL 60. This diagram illustrates the permissible uniformly distributed loads applied to multiple supports. They comply with IEC 61537 par 10.3.3 test type III with connection to 1/5 of the span.

F = max. admissible load (daN/m)

L = support distance (m)

Max. deflection (m) = L/100

KL 85

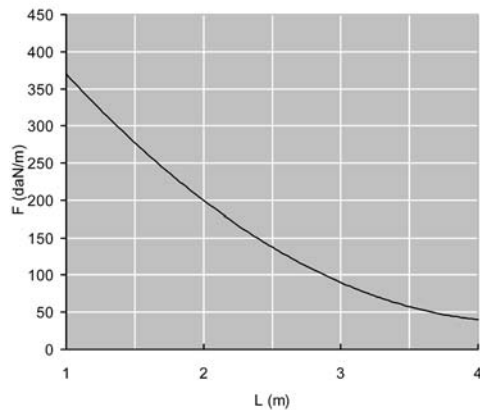

LOAD DIAGRAM

Graph valid for KL 85. This diagram illustrates the permissible uniformly distributed loads applied to multiple supports. They comply with IEC 61537 par 10.3.3 test type III with connection to 1/5 of the span.

F = max. admissible load (daN/m)

L = support distance (m)

Max. deflection (m) = L/100

KL 110

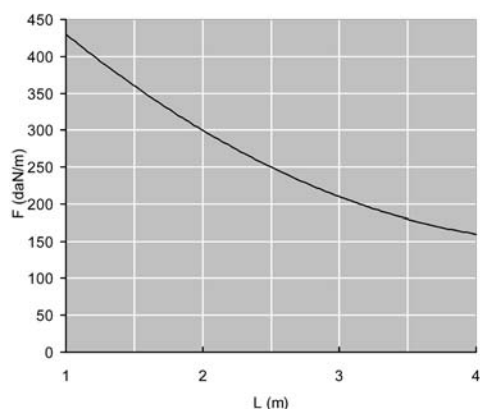

LOAD DIAGRAM

Graph valid for KL 110. This diagram illustrates the permissible uniformly distributed loads applied to multiple supports. They comply with IEC 61537 par 10.3.3 test type III with connection to 1/5 of the span.

F = max. admissible load (daN/m)

L = support distance (m)

Max. deflection (m) = L/100