

HDWK

Wand-/ Hängestielausleger geschweißt

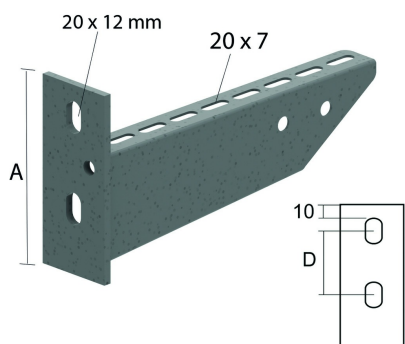

	Max. Belastung (in daN)	A	D
HDWK100	120	106,5	46,5
HDWK150	230	112	52
HDWK200	340	116	56
HDWK300	320	125	65
HDWK400	430	134	74

Referenz	↕ mm	↔ mm	→ ← mm	↔ mm	kg/stk	📦	Einheit
HDWK100	106	117			0,300	12	STK
HDWK150	112	167			0,360	12	STK
HDWK200	116	217			0,430	12	STK
HDWK300	125	317			0,730	12	STK
HDWK400	134	417			0,880	6	STK

Zu befestigen mit:

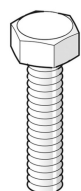

Sechskantschraube (DIN 933)
B

Sechskantmutter (DIN 934)
M



Großflächenunterlegscheibe (DIN 9021)
CRO

Verwenden Sie B12.50 + CRO12 + M12 für symmetrische Befestigung.

