

PNK

Gleitmutter mit PVC-Halter

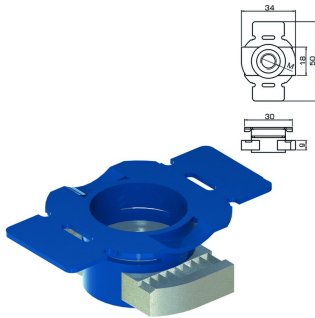

Referenz	L mm	A mm	g mm	↔ mm	kg/stk	📦	Einheit
PNK08	50	34	6		0,020	25	STK
PNK10	50	34	6		0,020	50	STK
PNK12	50	34	8		0,030	25	STK