

P1186

Fitting angle 135° 2D14

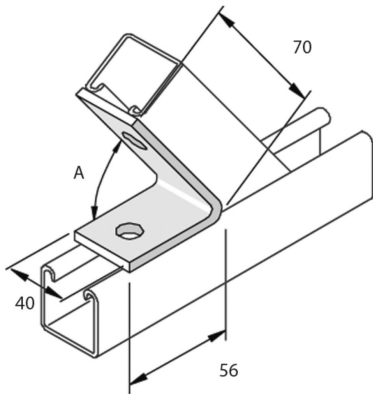

Reference	Finish	↕ mm	↔ mm	→ ← mm	↔ mm	kg/stk	📦	Unit
P1186	HG		40		56	0,188	20	STK

A = 45°

Abbreviation:

- HG = Hot-Dip Galvanised

Legend finish

- HG = Hot-dip galvanised