

P1001

Assembly profile

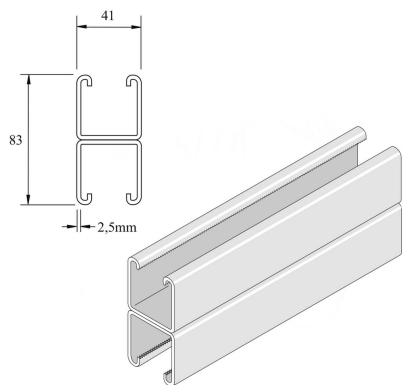

Reference	Finish	↑ mm	↔ mm	→ ← mm	↔ mm	kg/m	📦	Unit
P1001P	-	82	41	2,5	6000	5,505	150	M
P1001PG	ZP	83	41	2,5	6000	5,594	6	M
P1001PGX3000	-	82	41	2,5	3000	5,593	75	M
P1001	HG	83	41	2,5	6000	5,770	6	M
P1001X3000	HG	83	41	2,5	3000	5,770	3	M

Abbreviation:

- ZP = Zinc Plated
- HG = Hot-Dip Galvanised

Legend finish

- ZP = Zinc plated
- HG = Hot-dip galvanised